

## **Topics:**

15. B-lymphocytes - ontogenesis, surface markers, function.  
Ontogenesis of antibody production.
16. Immunoglobulins (structure, classes). Genetic background of immunoglobulin production. Anti-idiotypes.
17. Immunoglobulins (functions of different isotypes)
18. Antibodies based immune reaction (primary, secondary).
19. Mucous and cutaneous immune system (Barrier functions of the human body and defence mechanisms).
20. External regulation of immune response (possibilities, purposes).

# B-lymphocytes

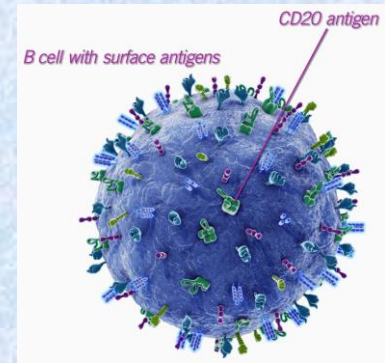

- B lymphocytes are a type of lymphocytes, which play a role in the humoral part of the specific (adaptive) immune system
- B-cells recognize native antigen through BCR (B cell receptor)
- B-lymphocytes which bind Ag with BCR are stimulated to proliferate and differentiate into effector plasma cells which produce large quantities of antibodies. Part of stimulated B-cells differentiate to memory cells.

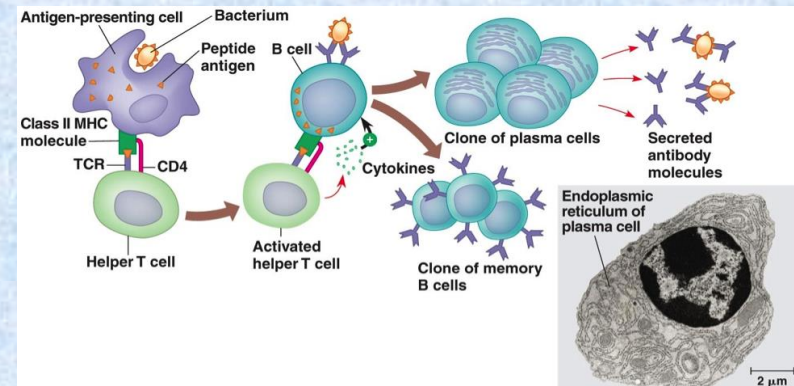

# Surface markers of B lymphocytes

- **CD 19, 20** - characteristic surface markers of B cells
- **IgM, IgD** - BCR
- **MHC gp II** - Ag presenting molecules
- **CD 40** – costimulating receptor

# BCR

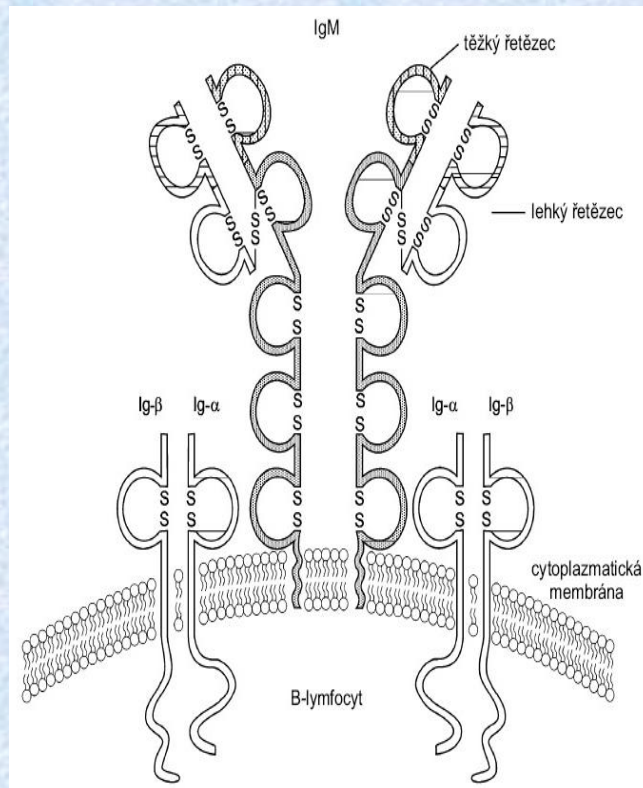

BCR is composed from surface immunoglobulin (IgM, IgD) which recognizes Ag and associated signaling molecules Ig $\alpha$  and Ig $\beta$ , which are associated with the cytoplasmic protein-tyrosine kinases (PTK)



# B cell development

- Development of B cells takes place in the bone marrow and completes after activation with Ag in secondary lymphoid organs.

## Pluripotent hematopoietic stem cell (CD 34)



**Pro - B cell** - begin recombination processes



**Pre - B cell** - expression of pre-B receptor  
(composed of H ( $\mu$ ) chain and alternate L chain)

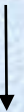

**Immature - B lymphocyte** - expression of surface IgM (BCR)



**Mature B lymphocyte** - expression of surface IgM and IgD (BCR)

# Negative selection

- If an immature B cell **binds** an antigen in the bone marrow with **high affinity** → further maturation is stopped and B cell dies by **apoptosis**
- **Negative selection** eliminates potentially dangerous cells that can **recognize** and **react** against **self antigens**
- B cells that survive this selection process leave the bone marrow through efferent blood vessels

# Immunoglobulins (Antibodies)

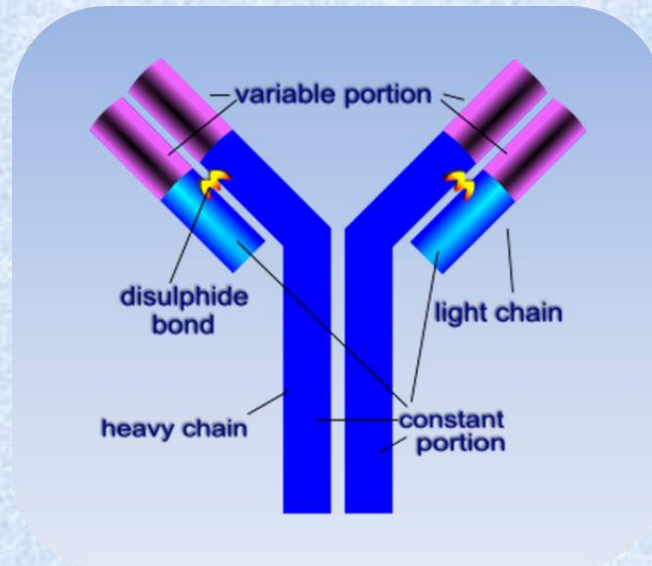

# Immunoglobulins

- Immunoglobulins or antibodies are glycoproteins, responsible for humoral part of **specific immune response**
- produced by B cells (plasma cells)
- secreted x membrane (BCR)

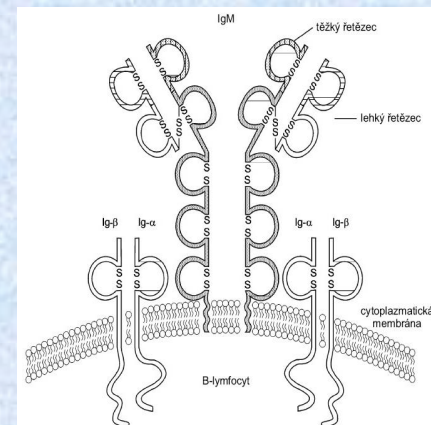
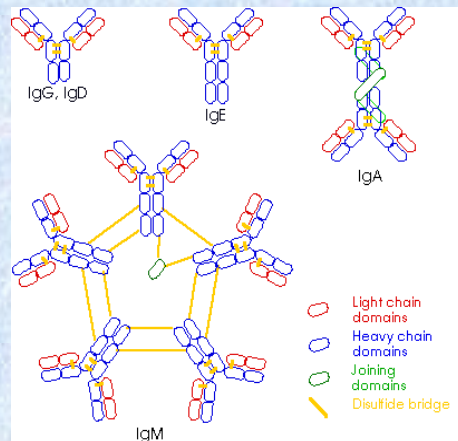



# Immunoglobulin structure

- 2 heavy (H) chains covalently linked by disulfide bonds, each H chain is connected to a light (L) chain by disulfide bonds
- H chain consists of 4 to 5 domains (1 variable, 3-4 constant)
- L chain consists of 2 immunoglobulin domains (1 variable, 1 constant)
  
- Types of L chains -  $\kappa$ ,  $\lambda$
- Types of H chains -  $\mu$ ,  $\delta$ ,  $\gamma$  ( $\gamma 1-4$ ),  $\alpha$  ( $\alpha 1$ ,  $\alpha 2$ ),  $\epsilon$

# Immunoglobulin structure

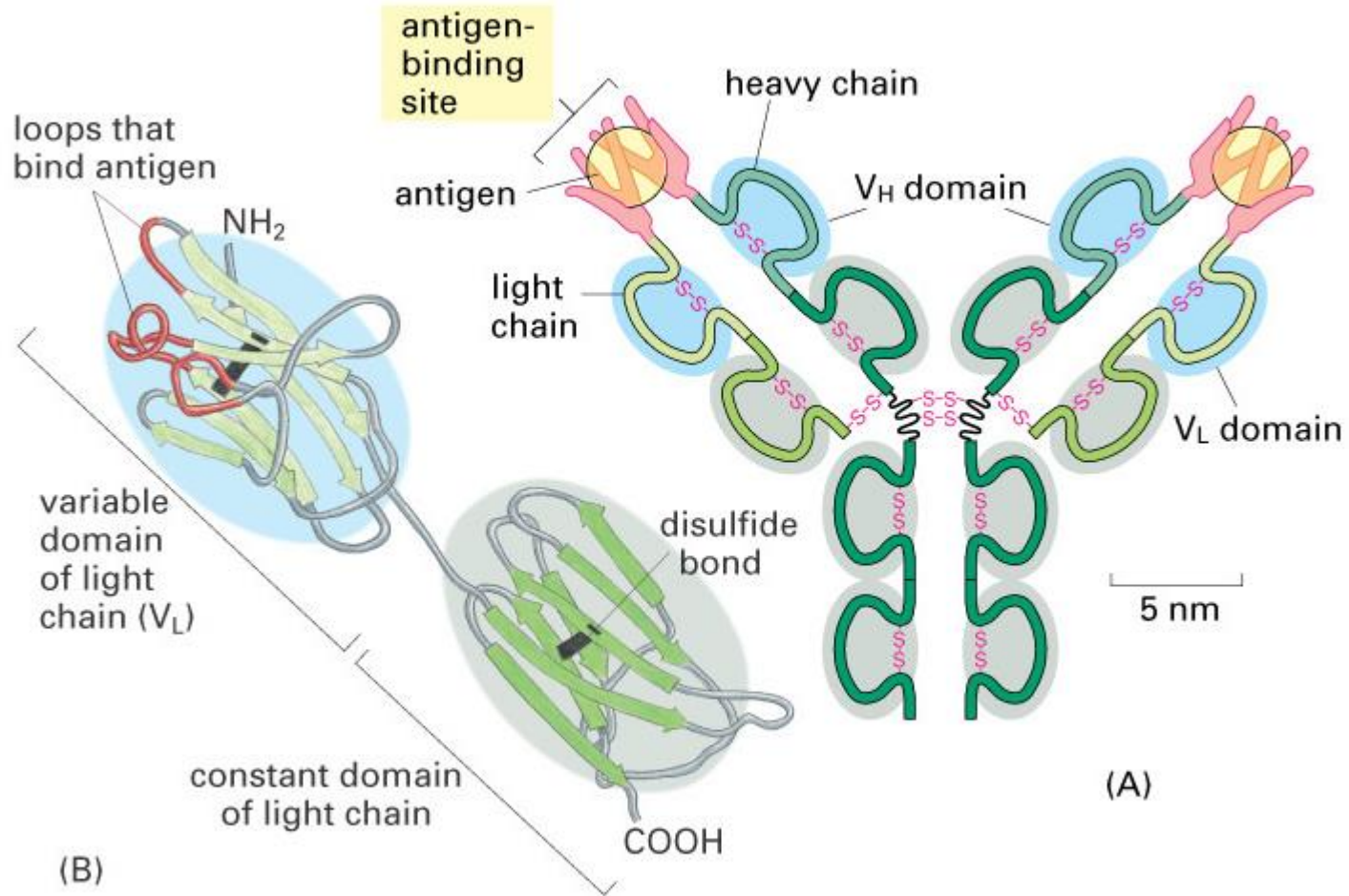

- Variable domains of L and H chain form **the binding site for Ag**
- **Hinge region** – place where are the heavy chains linked by disulfide bonds
- Immunoglobulins are glykoproteins (glycosylated **Fc part**)

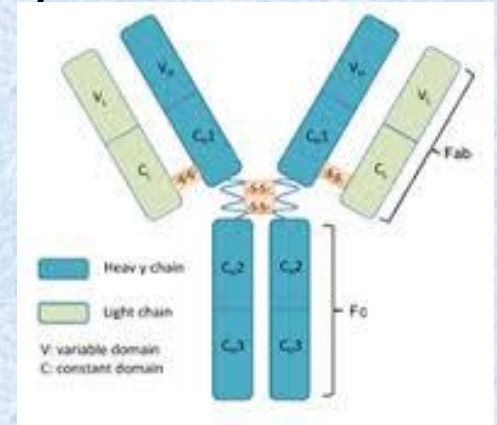

- **J chain** - molecules of immunoglobulin classes (IgM, IgA) consist of several monomer units – joined together by J chain
- **Secretory component** (IgA)

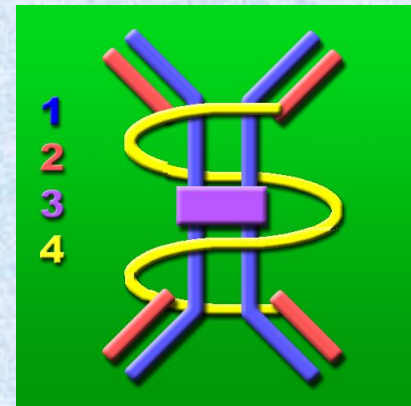



# Immunoglobulins functions

- **Antigen neutralization** Antibodies prevent bacterial adherence or inhibit activity of toxins, viruses and other microorganisms by binding to their important epitopes
- **Complement activation (IgM, IgG)** Antibody activates complement, which enhances opsonization and lyses some bacteria
- **Opsonization (IgA, IgG)** Antibodies promote phagocytosis by APC
- **Mast cell activation using IgE**
- **ADCC** (antibody-dependent cellular cytotoxicity)



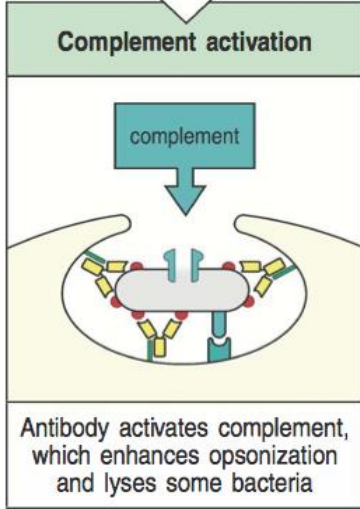
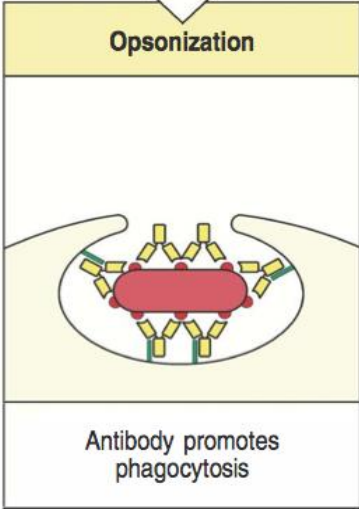
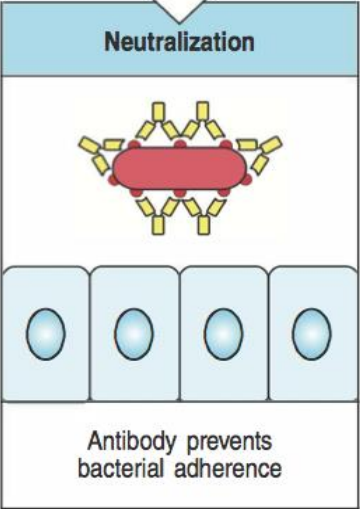
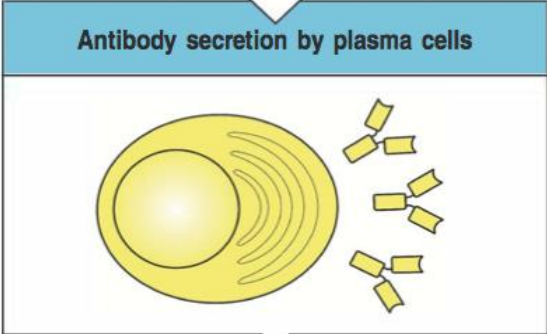
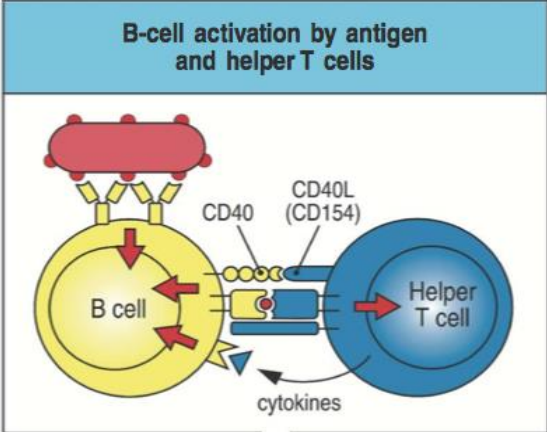

# Immunoglobulins functions

## ■ Mast cell activation using IgE

Basis of allergic reaction and of the defence against multicellular parasites

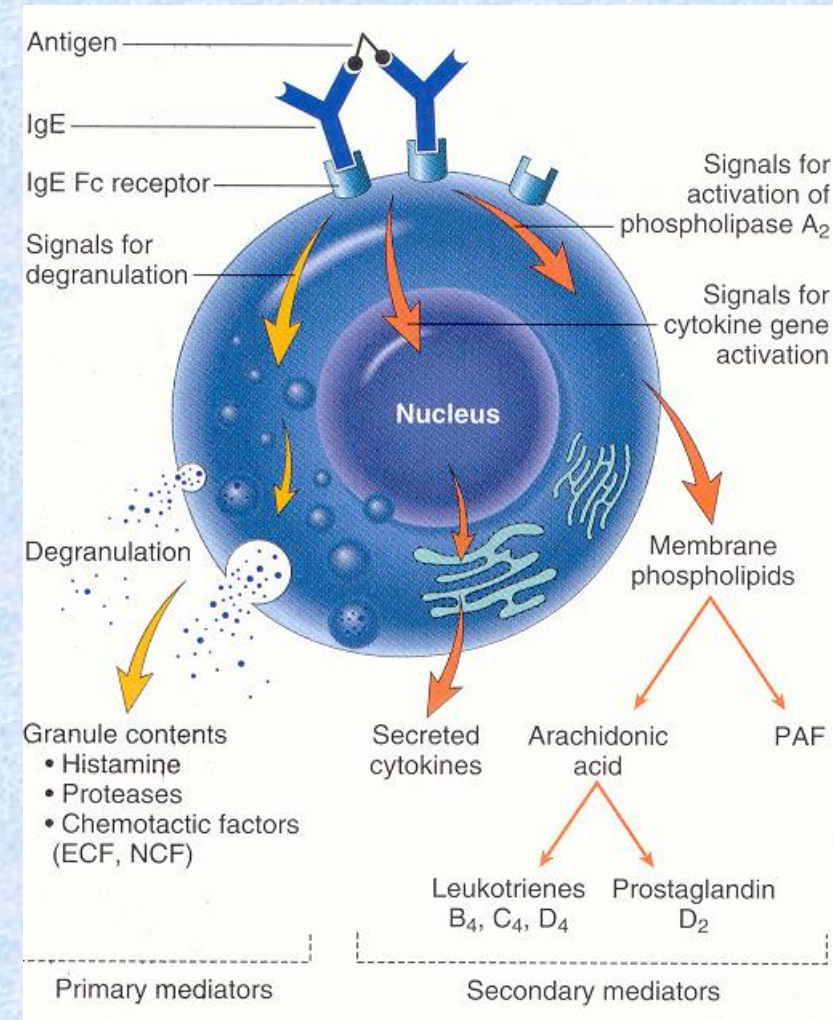



# Mast cell activation by cross-linking of IgE Fc receptors

Allergen or multicellular parasite binds to IgE on mast cell → cross-linking of several molecules FcεRI

- initiate mast cell **degranulation** (release of **histamin**, tryptase, serotonin...)
- **activation of arachidonic acid metabolism** (leukotriene C4, prostaglandin PGD<sub>2</sub>) - amplification of inflammatory responses
- **cytokine production** by mast cell (TNF, TGFβ, IL-4, 5, 6)

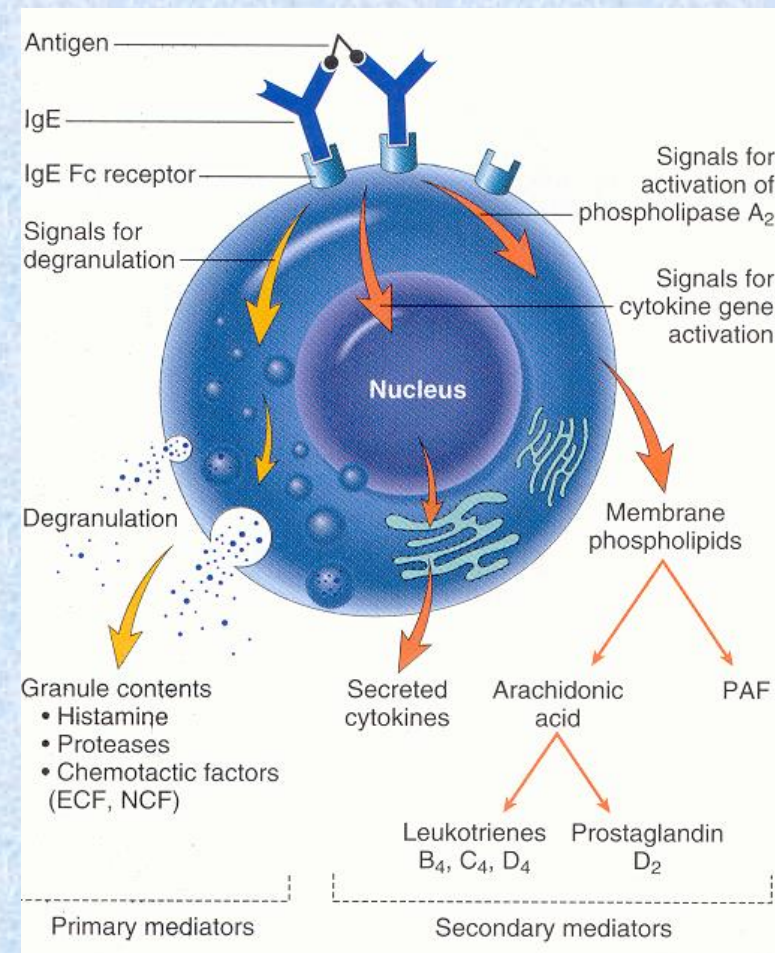

# Histamine

- vasodilatation, increase of vascular permeability (erythema, edema, itching)
- bronchoconstriction (cough, wheezing, dyspoe)
- increases intestinal peristalsis (diarrhea)
- increased mucus secretion (cough)

Responsible for the clinical signs of allergy.

Helps eliminate the parasite.



# Immunoglobulins functions

- **ADCC** (antibody-dependent cellular cytotoxicity) NK cells recognize cell opsonized with IgG antibodies by the Fc receptor CD16, this leads to the activation of cytotoxic mechanisms (NK degranulation)

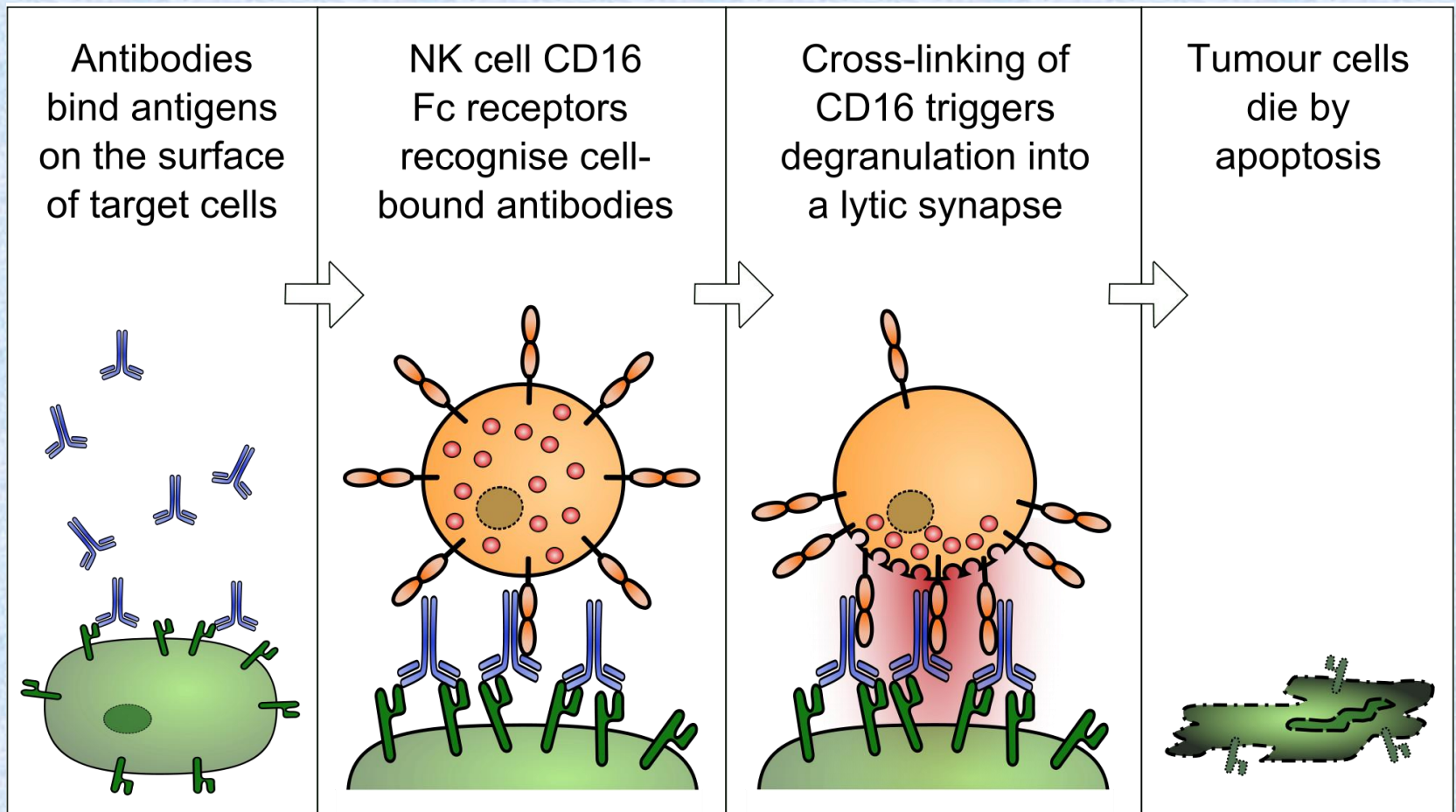

# Classes of immunoglobulins and their functions

- IgM, IgD, IgG (IgG1 - IgG4), IgA (IgA1, IgA2), IgE
- Distinguished by the constant part of H chain

- **IgM**

- first isotype that forms after the meeting with Ag
- as a monomer form BCR
- secreted as pentamer (10 binding sites)
- functions: Ag neutralization, complement activation, do not bind to Fc receptors on phagocytes
- (concentration of 0.9 to 2.5 g / l; biol. half-life 6 days)

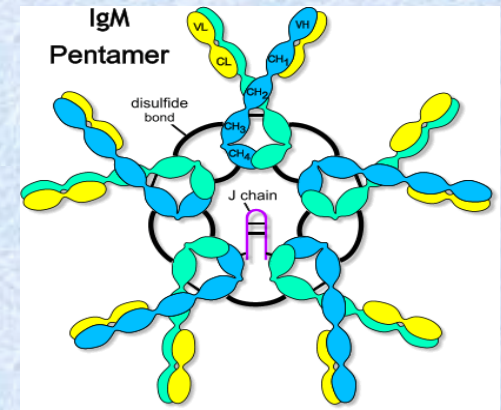

## ■ IgG

- predominantly formed in secondary immune response
- functions: Ag neutralization, opsonization, complement activation, ADCC
- isotypes IgG1-IgG4
- passes the placenta (protection of fetus in utero)
- (concentration of 8 to 18 g / l; biol. half-life of 21 days)

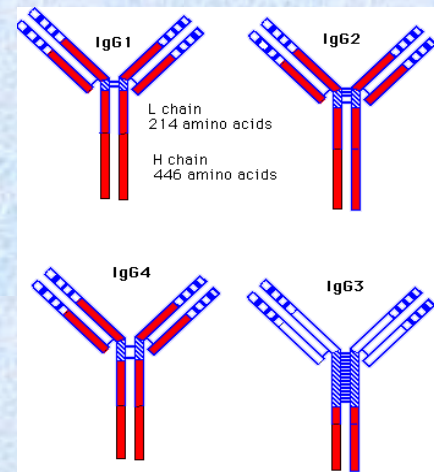

# IgA

## Secretory IgA

- most significant mucosal immunoglobulin
- provides protection of mucous membranes
- dimer with secretory component
- functions: Ag neutralization, opsonization, do not activate complement
- saliva, tears, breast milk

## Serum IgA

- monomer, dimer or trimer
- (0.9 to 3.5 g/l; biol. half-life of 6 days)

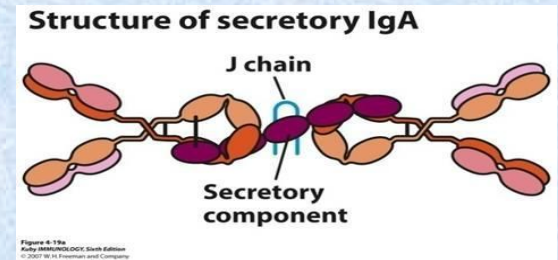



## ■ IgD

- forms a BCR
- in serum is in a very low concentration
- (0.1 g / l; biol. half-life 3 days)

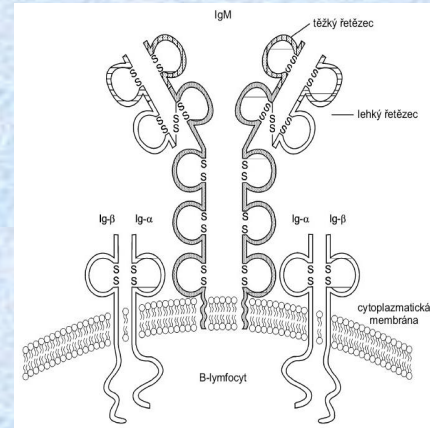

## ■ IgE

- applies in defense against multicellular parasites
- is the main cause of allergic reactions
- ( 0-100 kIU/l; biol. half-life 2 days)

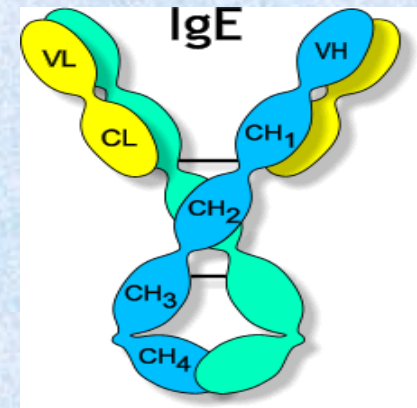

# The genetic basis of the immunoglobulins development

- **Gene segments for H chains** – on chromosome 14

**V** (variable) segments

**D** (Diversity) segments

**J** (joining) segments

**C** segments



variable domain of H chain

constant domains of H chain

- **Gene segments for L chains** -  $\kappa$  on chromosome 2  
-  $\lambda$  on chromosome 22

**V** (variable)

**J** (joining)

**C**



variable domain of L chain

constant domain of L chain

- At the ends of V, D, J segments there are signal sequences which are recognized by enzyme VDJ recombinase that carry out the rearrangement of these genes
- On the sides of C segments are so-called switch sequences, which are recognized by enzyme recombinase that carry out isotype switching

# The rearrangement of genes coding H chain

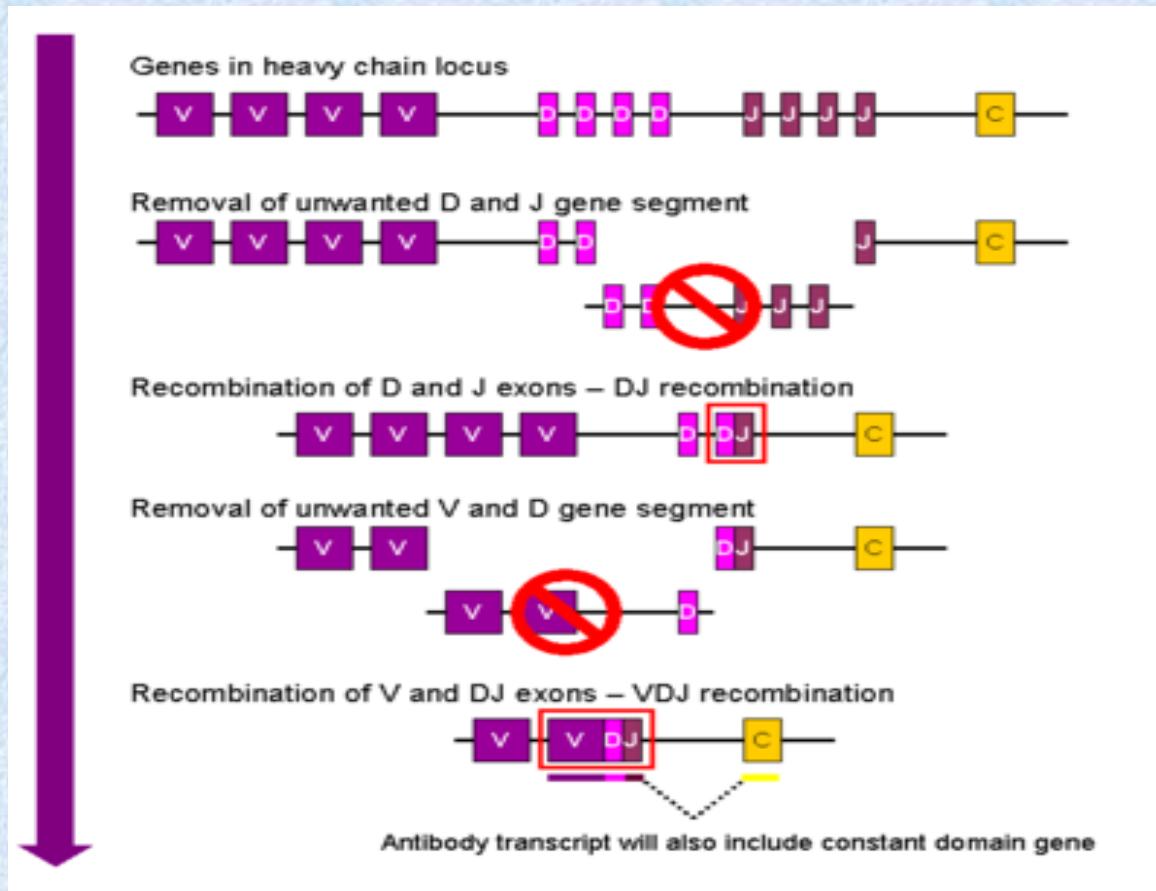

**1) DJ rearrangement** - excision a section of gene complex between some D and J segment

**2) VD rearrangement** - excision a section between some V segment and DJ

The rearranged IgH gene is transcribed into mRNA

# The rearrangement of genes coding H chain

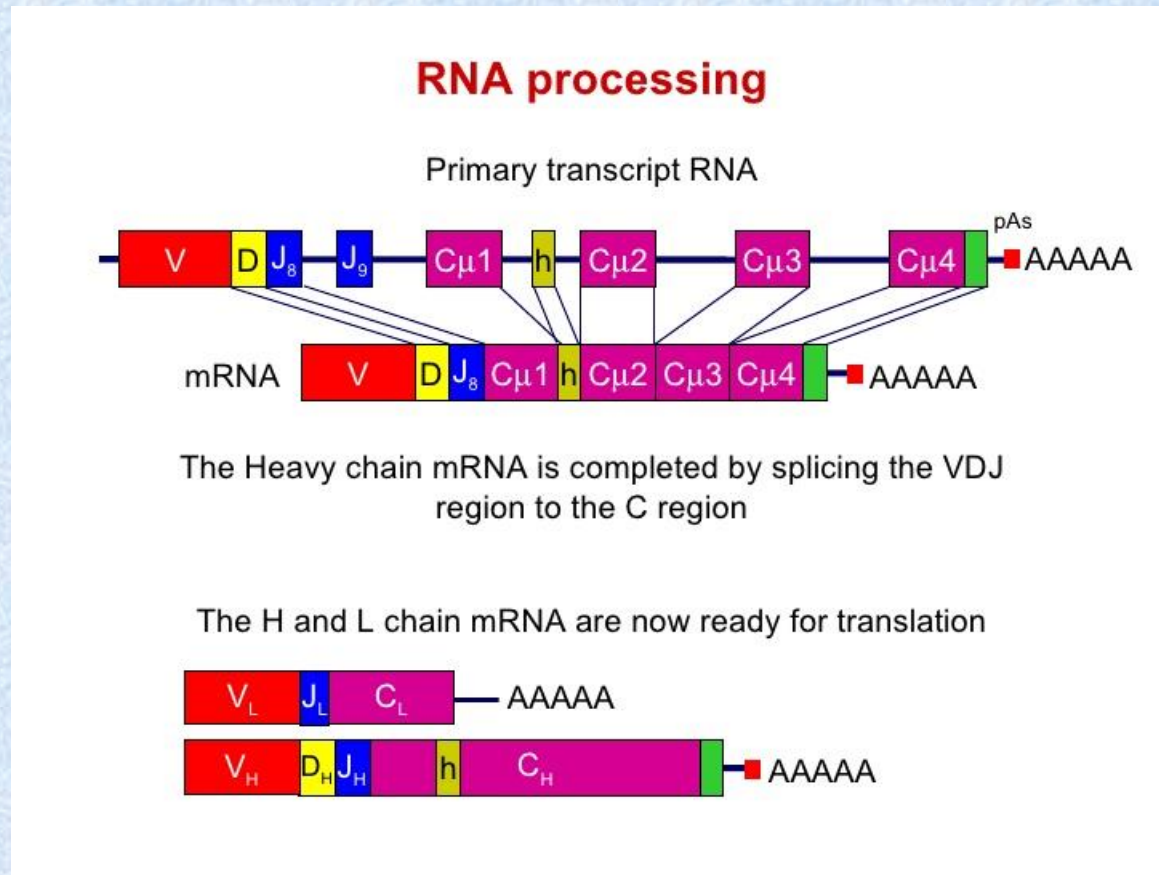

The first formed H chain is  $\mu$ .



# The rearrangement of genes coding L chain

- 1)** First, rearrange the genes encoding the L chain  $\kappa$ , there is excision of sections between a V and J segment
- 2)** If regrouping of the  $\kappa$  genes is unsuccessful, start the regrouping genes  $\lambda$ .

# Isotype (class) switching

- Occurs during the terminal differentiation of B lymphocyte after activation with Ag on the surface of FDC
- Enzymes recombinases recognize the switch sequences located on the sides of C segments and excise gene segments
- After elimination of some C segment, the closest segment to VDJ segment is transcribed into mRNA, and after splicing and translation arise corresponding isotype of the H chain

# Isotype switching

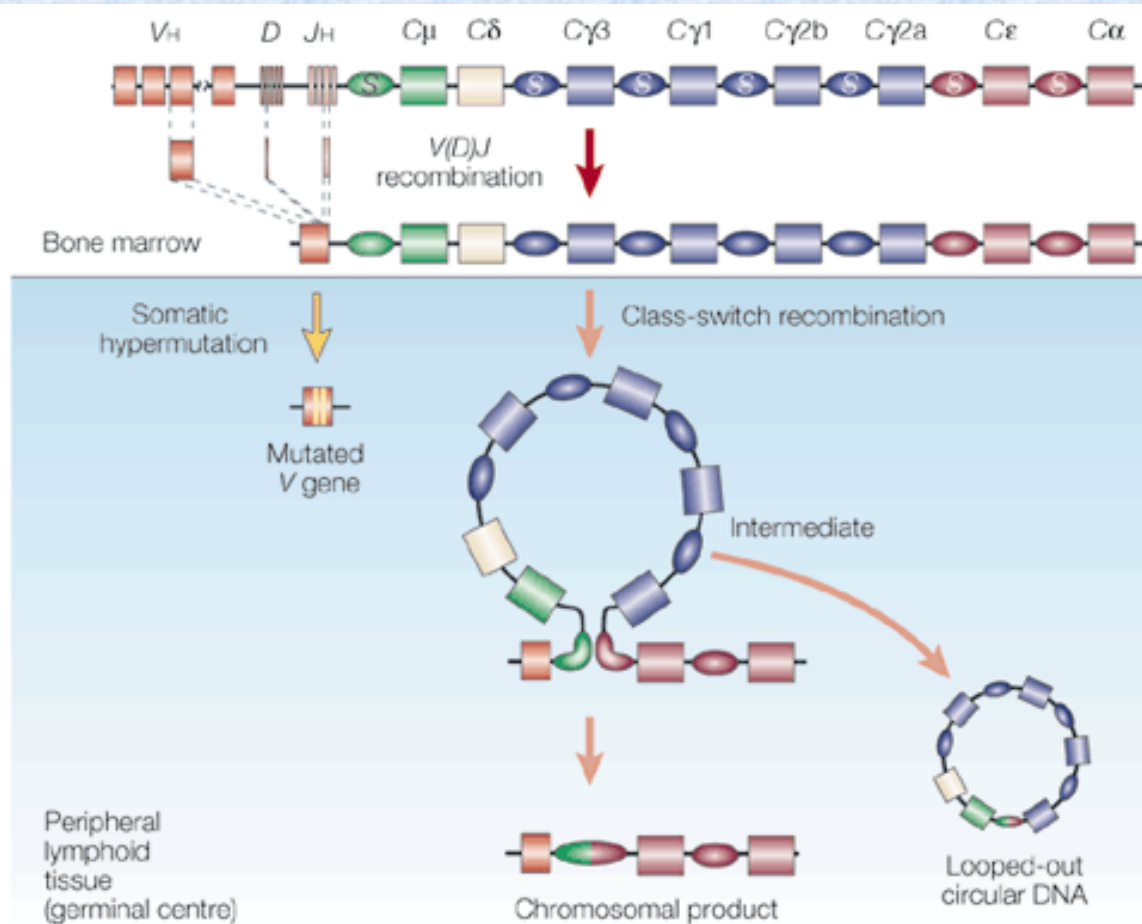

# Isotype switching

- Cytokines regulate which isotype will be produced:

IL-4 stimulates switching to IgE and IgG4

TGF $\beta$  stimulates switching to IgG2 and IgA



# Anti-idiotypic antibodies

- **IDIOTYP** = group of idiotops which are located on the variable part of antibody

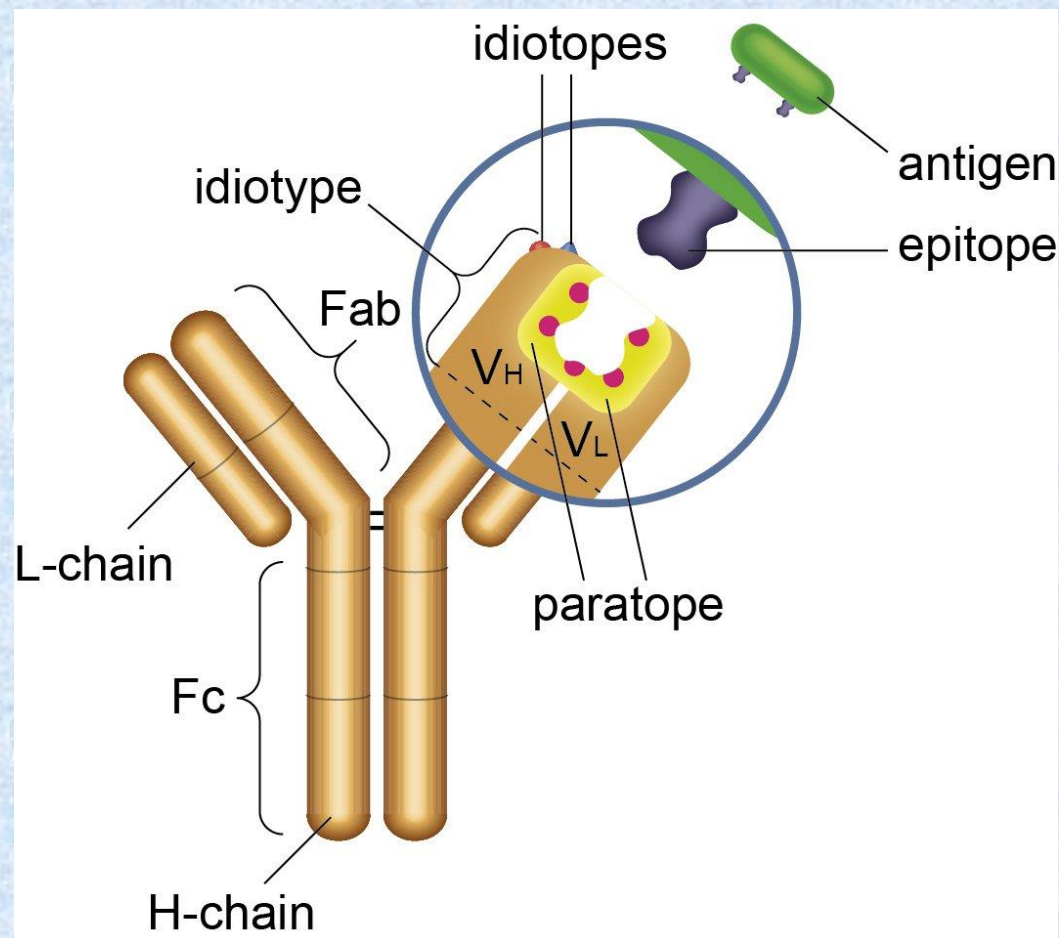

# Anti-idiotypic antibodies

- Idiotypic structures of 1st generation antibodies can be recognized by some B cells as antigens and can induce production of anti-idiotypic antibodies (2nd generation antibodies; some binding sites may remind Ag, which caused formation of 1st generation antibodies)
- Against the 2nd generation antibodies formate antibodies of 3rd generation (anti-antiidiotypic antibodies).
- The idiotypic network may play a role in regulation of antibody response

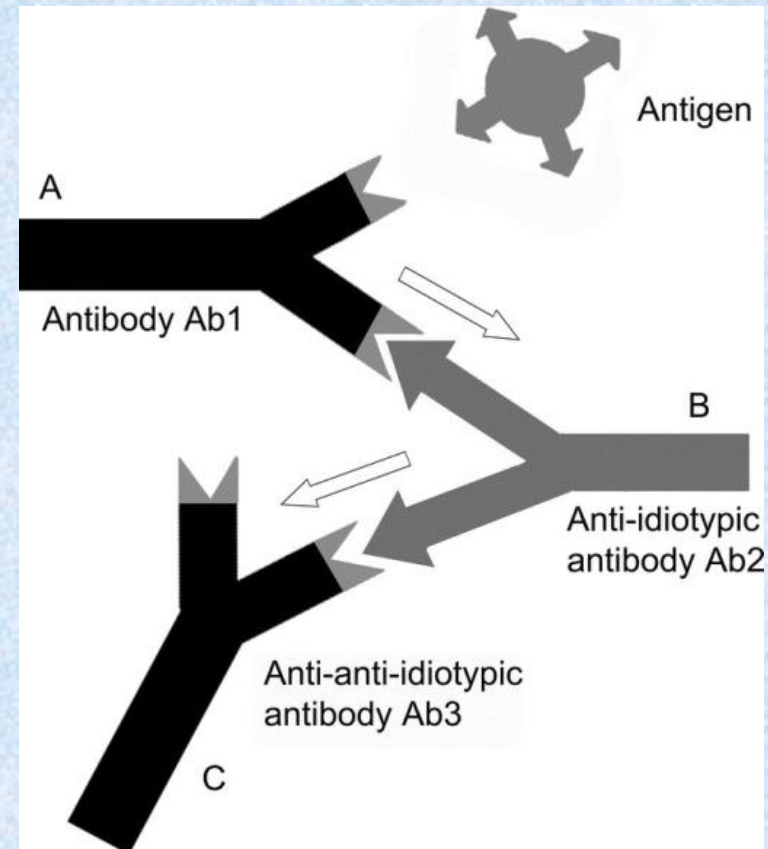

# Ontogenesis of antibodies

- Synthesis of specific antibodies begins around the 20.-24. week of gestation, the total concentration of IgA and IgM remains undetectable until birth, IgG begins to form after birth

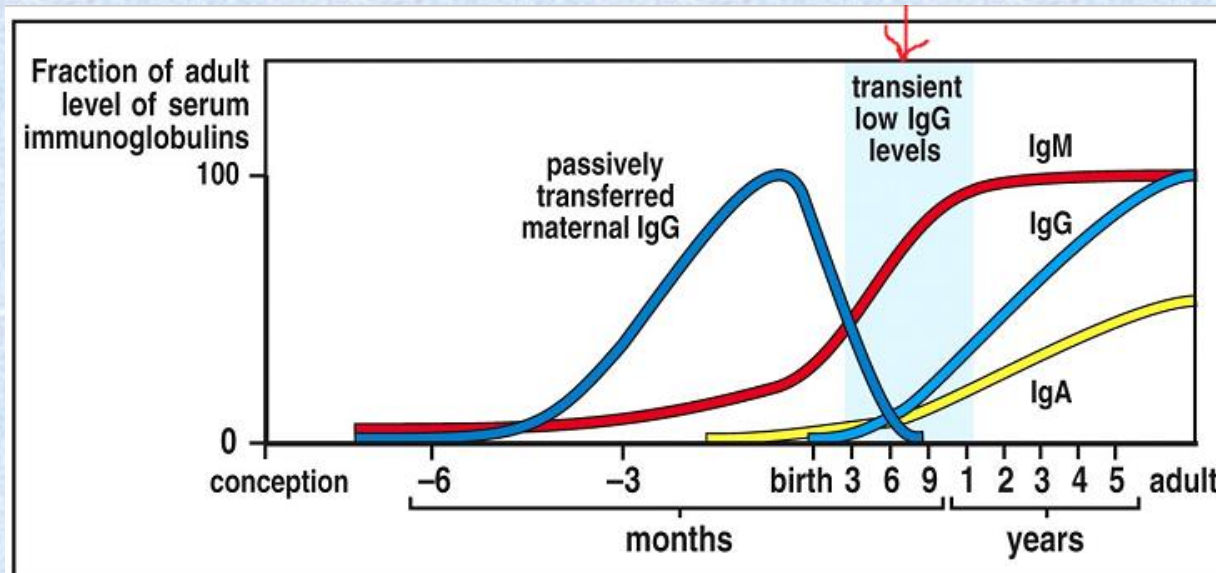
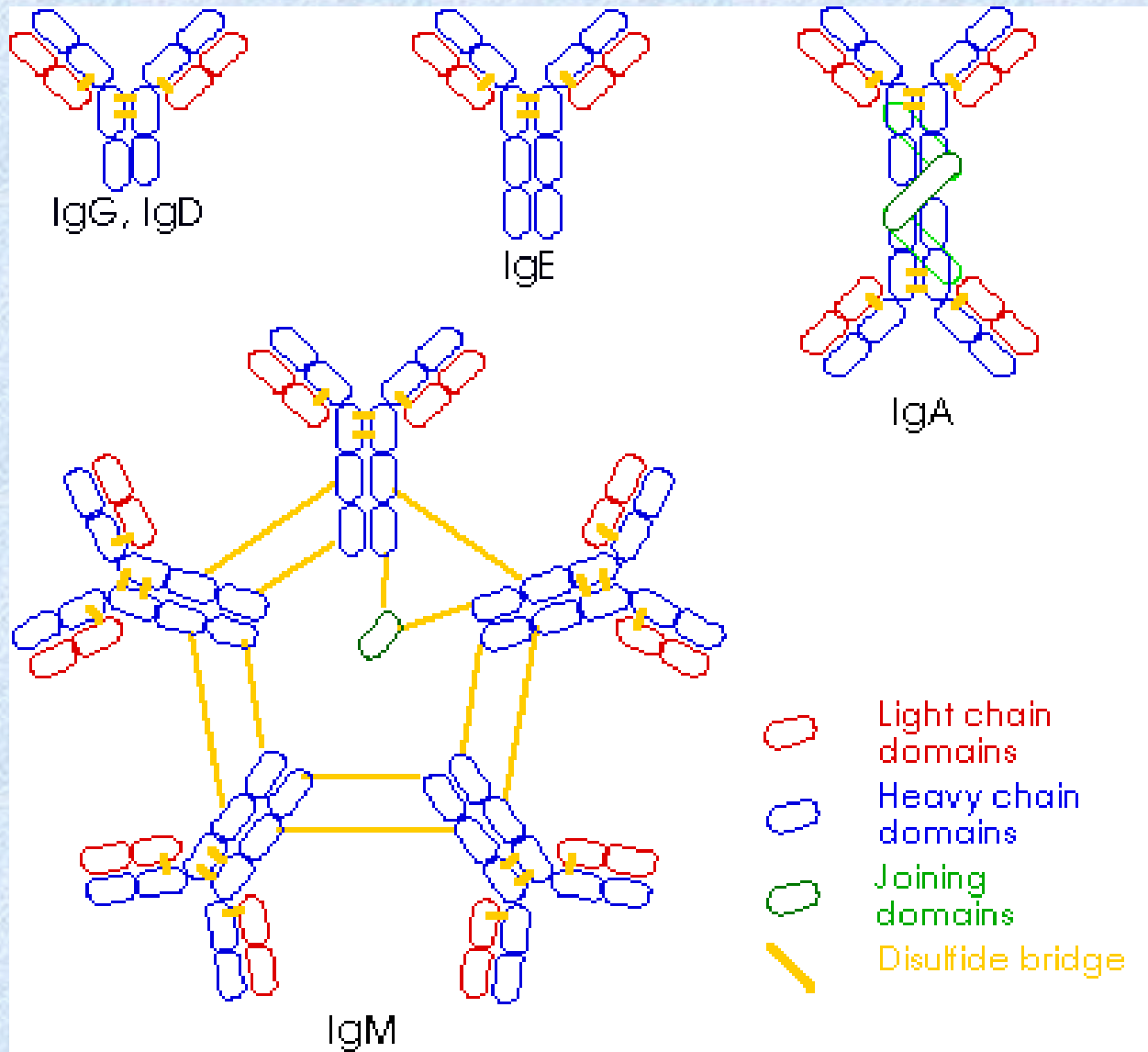

Figure 11-11 Immunobiology, 6/e. (© Garland Science 2005)

After birth begins slow growth of own IgG, which is accompanied by decline in maternal IgG (about 3. to 6.month)

- The IgM concentration reaches values comparable with adults in the 1- 3 year of life, IgG and IgA between 10.-15. year

# Immunoglobulins summary





# **Humoral immune response**

# Humoral response induced by

- **T-independent antigens**

- Cause predominantly IgM production
- Bacterial polysaccharides, lipopolysaccharides

- **T-dependent antigens**

- Reaction to these Ag occurs in two phases - primary and secondary
- Initiate the development of memory cells and formation of high-affinity antibodies and different isotypes
- Most of antigens (proteins)

# T-independent and T-dependent immune response

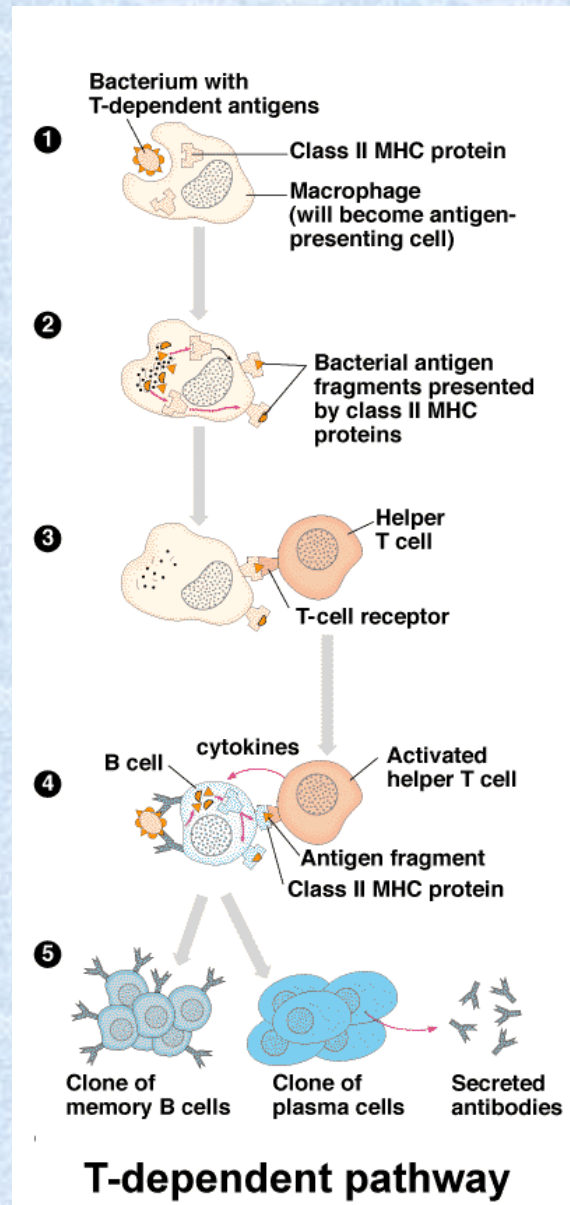
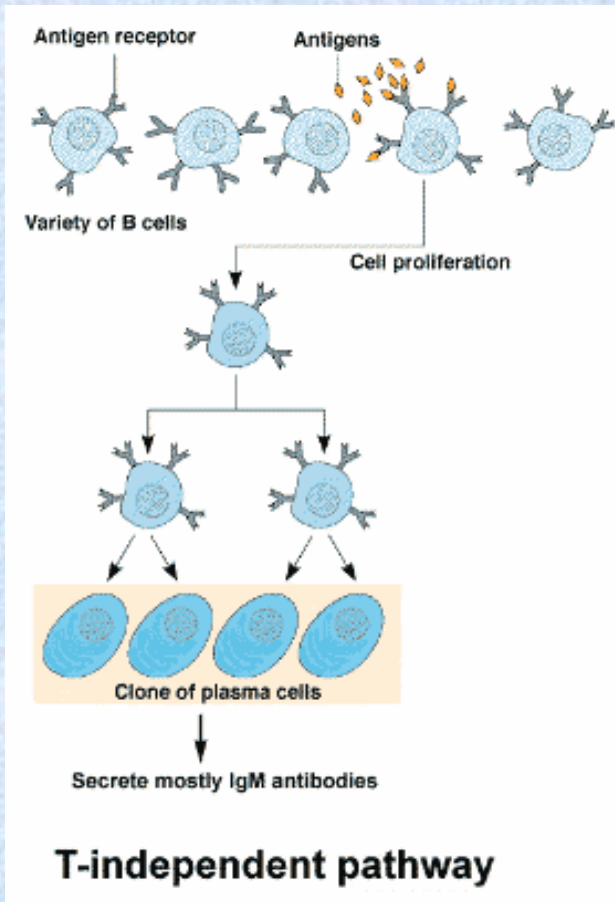

# T dependent immune response

## Primary phase of antibody response

- Takes place in secondary lymphoid organs
- After the first contact with Ag 2 processes run simultaneously:
  - **stimulation of B** cells by Ag binding to BCR
  - Ag **absorption by APC** and its **presentation** via MHC gp class II to precursors of  $T_H$  cell → formation of clone of antigen-specific  $T_H2$  cells

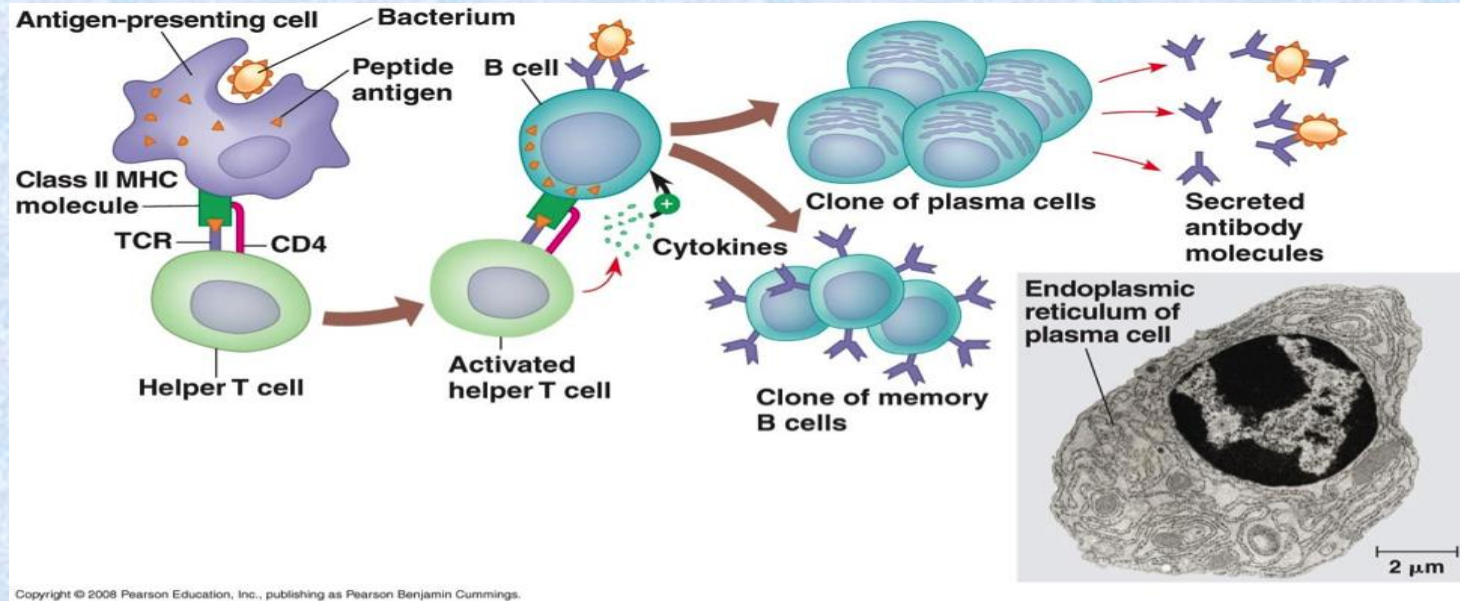



# Antigen presentation by B lymphocyte to Th2 lymphocyte

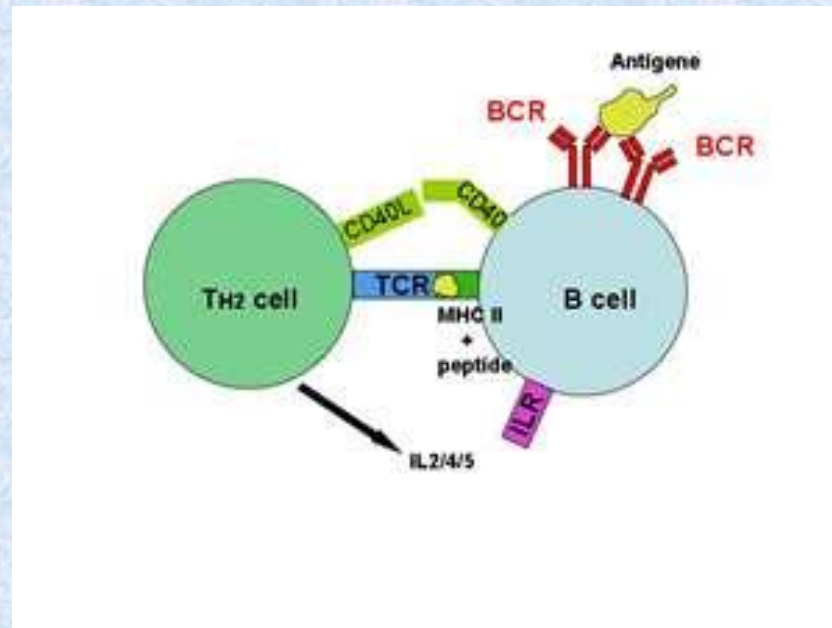

- Antibodies produced in the primary phase (3-4 days) are **IgM** and have a low affinity for Ag, create with Ag immune complexes
- Immune complexes are captured in the secondary lymphoid organs on the surface of **FDC** (follicular dendritic cells) - Ag presenting cells to B lymphocytes

## **Secondary phase of antibody response**

- When antigens in immune complexes on the surface of FDC are recognized by B cells, another cycle of proliferation and differentiation of B cells begins (with assistance of Th2 cells)
- Takes place in germinal centres (contain B, Th2 and FDC) of newly formed secondary lymphoid follicles = **Germinal center reaction**

## Secondary phase of antibody response

- This process is accompanied by somatic mutations of V segments of H and L chains → production of antibodies with higher affinity to Ag (4-6x higher) = **affinity maturation of antibodies**
- Besides somatic mutations also **isotype switching** starts- instead of IgM other isotypes of immunoglobulins are produced, which isotypes (IgG, A, E) arise determines cytokine environment
- In the secondary phase of the immune response are generated antibodies with **higher affinity to Ag** and with **other effector characteristics**, dependent on isotype. During this phase also **memory cells** are formed, prepared for next meeting with the Ag



# Primary and secondary immune response

## Primary immune response

- occurs after the first exposure to antigen
- long lag phase, low titre of antibodies, predominantly IgM

## Secondary immune response

- occurs after subsequent encounter with the same antigen and is more rapid due to the activation of previously generated memory cells
- prompt, powerful, much higher level of antibodies, predominantly IgG

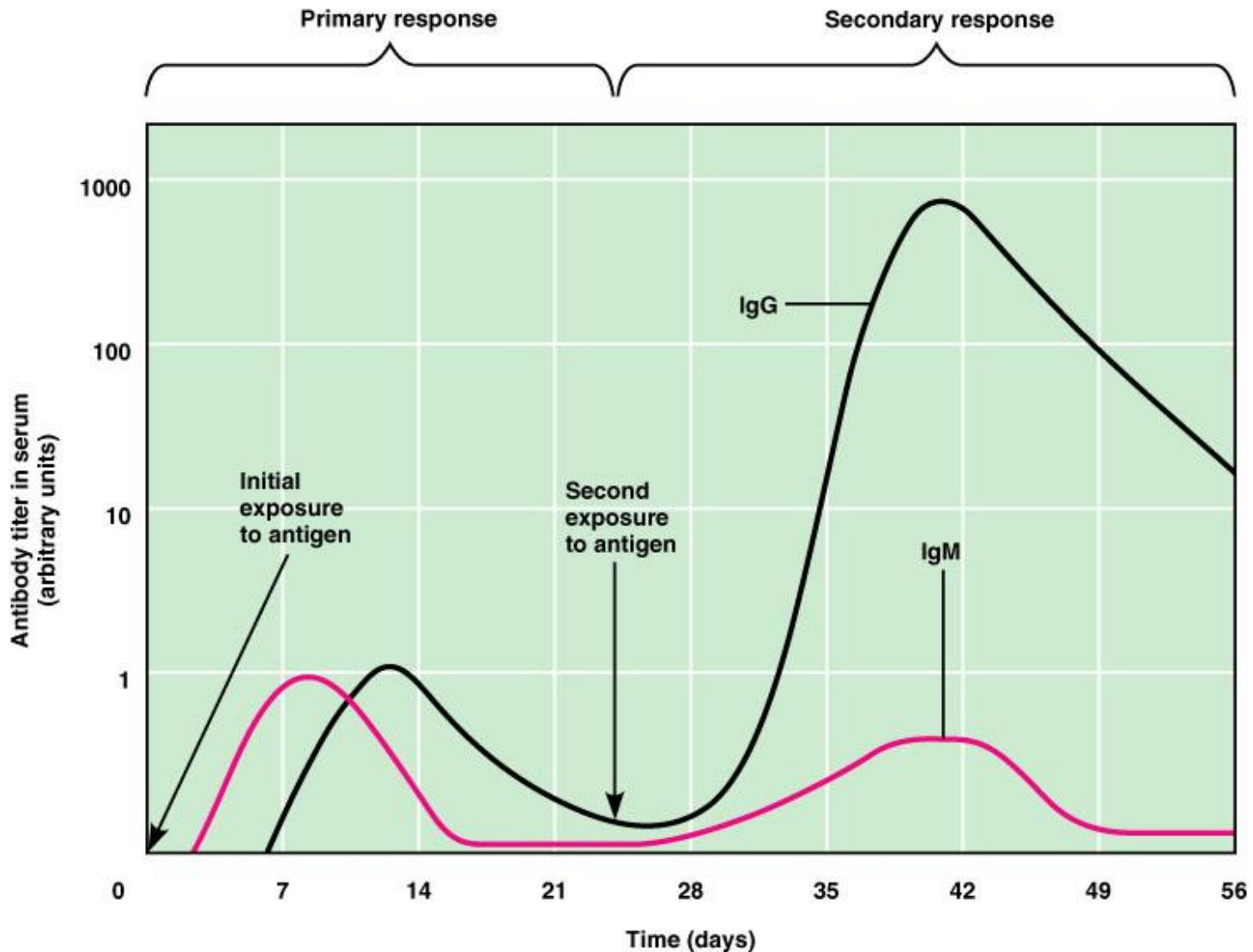

**Mucosal and skin  
immune system**

# Function and structure of the mucosal and skin immune system

Mucous membranes and skin are in constant contact with the outside environment, there is concentrated about 80% of immunocompetent cells.

**Skin** - barrier against mechanical, physical and chemical damage, and against the penetration of microorganisms, humans surface about **1,5 m<sup>2</sup>**

**Mucosal immune system** - prevents the penetration of pathogenic microorganisms, prevents the development of self-harm inflammatory immune responses against pathogens and harmless antigens from the external environment, mucosal surface about **400 m<sup>2</sup>**



# Barrier functions of the human body and defence mechanisms

## Non-immunological defense mechanisms:

**Mechanical barriers** – intact skin and mucus, movement of cilia, coughing, sneezing, the flow of air and fluids, vomiting, diarrhea

**Chemical inhibitors** - secrets of exocrine glands with bactericidal effects (fatty acids , lysozyme, pepsin, defensins, acidic pH of the stomach and urine)

**Other factors** – body temperature (37°C), tissue oxygen tension, age, stress , physiological microflora

# Structure of mucosal immune system

**MALT** (mucous associated lymphoid tissue)

**BALT** (bronchus associated lymphoid tissue)

**GALT** (gut associated lymphoid tissue)

**NALT** (nasal associated lymphoid tissue)

**o-MALT** (organized) – consists of lymphoid follicles in the mucous membrane, tonsil and adenoids, appendix, Peyer patches

**d-MALT** (diffuse) – consist of leukocytes diffusely distributed in the lamina propria (T and B lymphocytes, macrophages, neutrophils, eosinophils and mast cells)

# Humoral immune mechanisms of the mucous system

## sIgA

- \* secretory immunoglobulin A
- \* most significant mucosal immunoglobulin
- \* transcytosis - IgA is transported across the epithelium using transport Fc receptor (polymeric-Ig receptor), on luminal side is IgA split off with the part of the receptor called secretory component, which protects Ig against intestinal proteases
- \* neutralize antigens on mucosal surfaces (immune exclusion), don't activate complement, binds to Fc receptors on phagocytes, in Peyer's patches may be immune complexes with IgA captured and can induce immune response

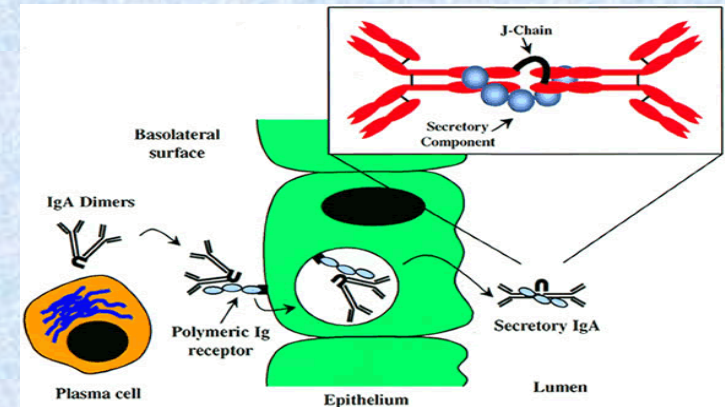



## Oral tolerance

- \* majority of antigens given orally induces suppression of specific immune response (critical is also the size of the antigenic particles, small particles are eliminated by immune exclusion)

**T<sub>r</sub> lymphocytes** (regulatory) - production of IL-10, TGF - beta

## Induction of mucosal immune response

- \* **M cells** - specialized enterocytes that provide transport of Ag (endocytose Ag from the surroundings)
  - are in close contact with lymphocytes and APC
- \* immunization in mucosa stimulates T<sub>H</sub>2 and T<sub>H</sub>3 lymphocytes and production of IgA

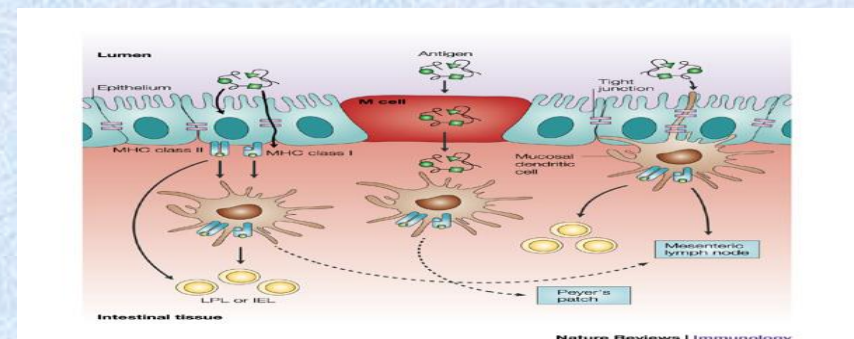



# **External regulation of immune response**

# Substitution treatment

- treatment with intravenous immunoglobulin (derived from plasma of blood donors)
- substitution of C1 inhibitor for hereditary angioedema
- substitution of erythropoetin in patients with chronic renal failure
- substitution of G-CSF in agranulocytosis

# **Non-specific immunosuppressive therapy**

used for treatment of autoimmune diseases, severe allergic conditions and for organ transplantation

- **corticosteroids** - anti-inflammatory, immunosuppressive effects
  - blocking the activity of transcription factors (AP-1, NF $\kappa$ B)
  - suppress the expression of genes (IL-2, IL-1, phospholipase A, MHC gp II, adhesion molecules)
  - inhibition of histamine release from basophils
  - higher concentrations induce apoptosis of lymphocytes
- **immunosuppressants affecting the metabolism of DNA**
  - cyclophosphamide, azathioprine, methotrexate
- **immunosuppressant selectively inhibiting T lymphocytes**
  - immunosuppressive ATB: cyclosporine A, tacrolimus, rapamycin
  - monoclonal antibody anti-CD3

# Anti-inflammatory and antiallergic treatment

- **nonsteroidal anti-inflammatory drugs**
- **antihistamines** - blocking H1 receptor
  - reduce the expression of adhesion molecules
  - reduce the secretion of histamine ...
- **Anti IgE antibodies (omalizumab)-**
  - severe allergic asthma



# Non-specific immunostimulant therapy

- **synthetic immunomodulators**

- **Methisoprinol** (Isoprinosine) - used in viral infections with more severe or relapsing course

- **bacterial extracts and lysates**

- **Broncho-Vaxom** - prevention of recurrent respiratory tract infections
- **Ribomunyl**

# Antigen-specific immunomodulatory therapy

- **specific immunomodulation** = induce an immune response or tolerance against a specific antigen

**a) active immunization**

**b) passive immunization**

**c) specific immunosuppression**

## **a) active immunization (vaccination)**

= the induction of immunity after exposure to an antigen

- protect against a pathogen bearing antigen or similar antigen (prophylaxis)
- immunization vaccines are made from inactivated or attenuated microorganisms or their antigens (polysaccharide capsule, toxins)
- creates long-term immunity
- activate cellular and antibody immunity
- administration of antigen s.c.

## b) passive immunization

- **natural** - transfer of maternal antibodies in fetal blood
- **therapeutically** - the use of animal antibodies against various toxins (snake toxins, tetanus toxin, botulinum toxin)
- **prophylaxis** - the human immunoglobulin from immunized individuals (hepatitis A, rabies, tetanus)
  - Anti-RhD antibodies - preventing maternal immunization with RhD<sup>+</sup> fetus
- provides a temporary (3 weeks) specific humoral immunity



## **c) specific immunosuppression**

= induction of tolerance against a specific antigen

- allergen immunotherapy (pollen, insect venoms)

- [https://www.youtube.com/watch?v=jPqb1\\_pE41g&list=PLNMRRM8YNM-urW9d6KrbkeW2nakXFm0zl9&index=1](https://www.youtube.com/watch?v=jPqb1_pE41g&list=PLNMRRM8YNM-urW9d6KrbkeW2nakXFm0zl9&index=1)

**Thank you for your attention !**

